

AVAILABLE MOUNTING CONFIGURATIONS

1.5VH-CC CLOSE-COUPLED

OPERATING LEVELS

MIN FLOW	48 GPM	11 m ³ /h
MAX FLOW	330 GPM	76 m ³ /h
DISCHARGE SIZE	1.5"	38 mm
SUCTION SIZE	2"	51 mm
MAX IMPELLER DIA.	8"	20.3 cm
SOLIDS HANDLING	.31"	8 mm
MAX SPEED	3600 RPM	3600 RPM
MAX PRESSURE	175 PSI	1207 kPa
SHUT-OFF HEAD	260'	79.3 m
BEP HEAD	185'	56.4 m
BEP FLOW	210 GPM	48.3 m ³ /h
BEP	69%	69%

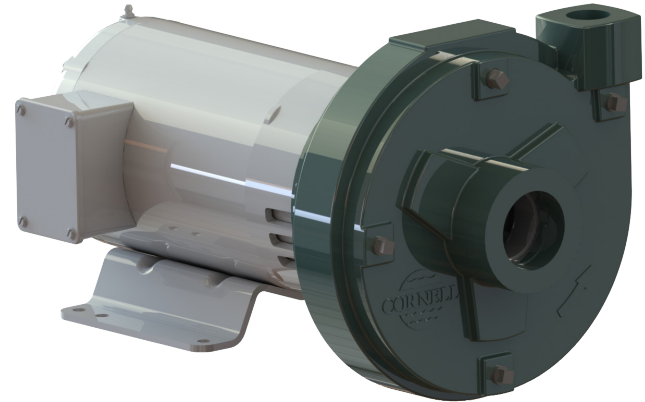

A typical picture of the pump is shown. Please contact Gemstone Pump Company for further details. All information is approximate and for general guidance only.

The 1.5VH pump is designed with Gemstone's renowned quality and durability. It features a 1.5" discharge, 2" suction, tangential volute and enclosed impeller. A type 21 single mechanical seal is standard, with Buna-N elastomers, stainless steel hardware and silicon carbide vs. silicon carbide seal faces. The 1.5VH comes standard with an open drip-proof motor that operates between 1800 and 3600 RPM; other motor options are available including TEFC and others.

- Standard iron construction with stainless shaft sleeve
- Back pull-out design
- Replaceable suction wear ring and shaft sleeve
- High efficiency hydraulics
- Low operating costs
- Two-year warranty
- Other mechanical seal options available
- FIPT connections

PARTS	STANDARD MATERIAL
WEAR RING	DUCTILE IRON
IMPELLER	CAST IRON
VOLUTE CASING	CAST IRON
SHAFT	CARBON STEEL
SHAFT SLEEVE	303 STAINLESS STEEL
BACKPLATE / BRACKET	CAST IRON
MECHANICAL SEAL	T-21, BUNA, SILICON CARBIDE FACES
MOTOR	ODP W/ 1.15 SF



AGRICULTURE



FOOD



INDUSTRIAL



MINING



MUNICIPAL



OIL & GAS



REFRIGERATION



RENTAL

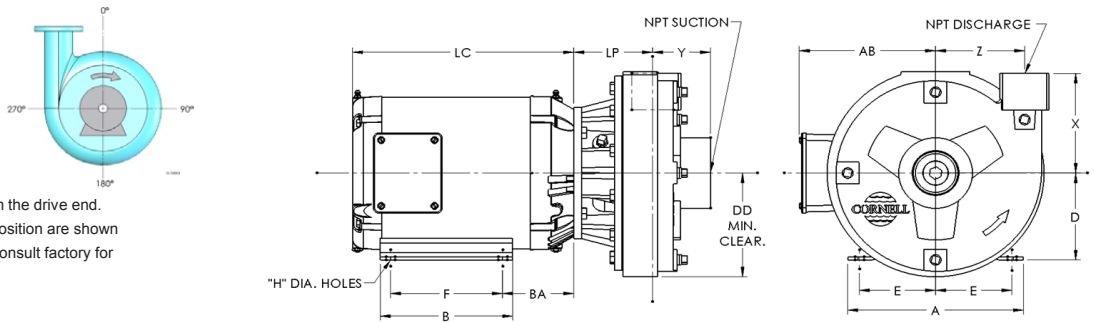
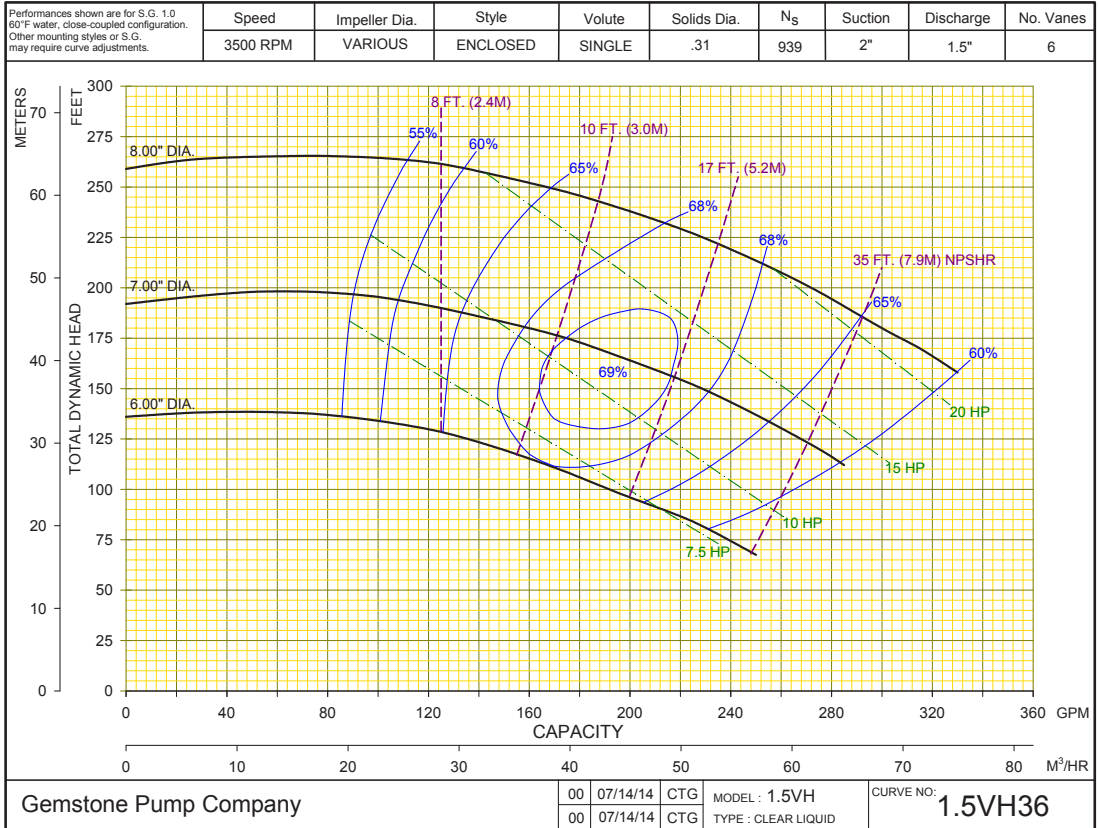

NOTES:

Discharge positions are viewed from the drive end. Standard increments of discharge position are shown in the chart below (DISCH INCR). Consult factory for other discharge positions.

PUMP DIMENSIONS*									
MODEL	CONNECTION		DISCH. INCR.	AK DIM.	DD	X	Y	Z	LP
	DISCH.	SUCT.							
1.5VH	1½ NPT	2 NPT	90°	4.5	5¾	5½	2¾	4½	3¾
	1½ NPT	2 NPT	90°	8.5	5¾	5½	2¾	4½	4
	1½ NPT	2 NPT	90°	8.5	5¾	5½	2¾	4½	see factory
	1½ NPT	2 NPT	90°	12.5	5¾	5½	2¾	4½	see factory

*Consult Factory for Motor Dimensions