

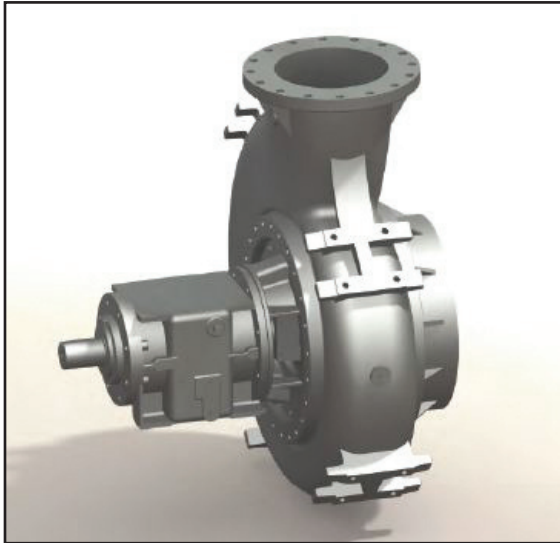

# 16NHG22F12DTR

Efficient by Design



## STANDARD SPECIFICATION

DISCHARGE	40.6 cm discharge
SUCTION	40.6 cm suction
IMPELLER	Enclosed, threaded, 3 vane: handles 11.43 cm solids
VOLUTE	Centerline discharge
MECHANICAL SEAL	See Cycloseal® design below
MATERIALS OF CONSTRUCTION	Cast iron casing, cast iron impeller

## CYCLOSEAL® DESIGN

Gemstone's Cycloseal® design, with its unique deflector vanes, works with the impeller backvanes to create a cyclo-action. This action removes solids and abrasive material from the seal area while purging air and gas pockets – extending seal life and eliminating any need for venting or water flush. The Cycloseal® design is available in all solids handling pumps and many clear liquids, hot oil and food handling pumps.

## MOUNTING OPTIONS

FRAME MOUNT	F12dtr
Oil Filled Bearing Frame	Optional
Redi-Prime® Self Priming system	Optional

## FEATURES AND BENEFITS

- **Highest quality products**
- **Experience**
  - Over 50 years in the centrifugal pump business
- **Optimum Hydraulics**
  - In house engineering staff and test lab
- **Exceptional design and efficiency**
  - Converts energy into fluid flow and pressure
- **Long product life**
  - Thick walled castings
  - Heavy duty shafts
  - 20,000 hour bearings
  - Replaceable wear rings and shaft sleeves

## CYCLOSEAL® BENEFITS

**Extended Seal Life:** Cornell's Cycloseal® design has proven itself in the toughest applications from manure slurry to starch recovery to clear water, food processing, self-priming and hot cooking oil applications – in some cases more than tripling the normally expected mechanical seal life.

**Run-Dry Option:** All pumps equipped with Gemstone's Cycloseal® system have an optional run-dry feature available, which serves to lubricate the seal faces even when there is no liquid in the pump casing. In situations where the pump must run dry for several hours, or where the pump may suddenly lose prime without being shut off, the Run-Dry™ feature is a must.

**System Savings:** The Cycloseal® system requires no external water flush, filters, grease cups, piping or instrumentation normally associated with packing or double mechanical seals.

**Maintenance Savings:** Longer seal life which translates into less pump down time and lower maintenance costs.

# 16NHG22

