

# 30NNT-F

## DATA SHEET

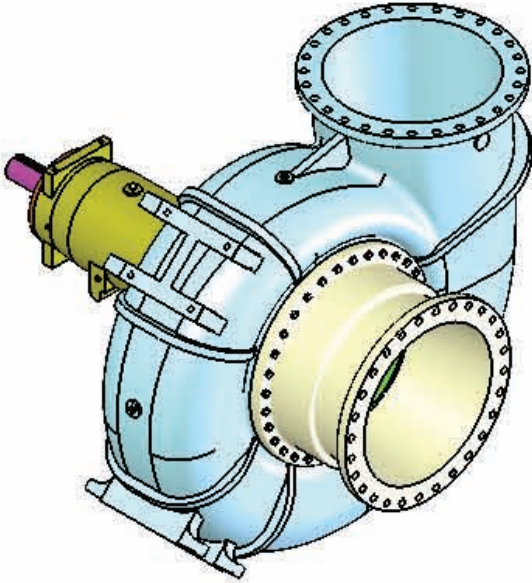

Pumps are made from all iron, horizontal (F) and vertical (VF) configuration with enclosed cast iron impeller, 416 stainless steel shaft sleeve, packing or Cycloseal or double seal, and single casing cast iron wear ring, frame except 4NNTL. All pumps incl. volute clean-out hole & cover.

- **Materials:** Other materials are available by special order. See solids handling accessories page for price adders (alloy shaft materials).
- **Bearing Lubrication:** Oil lubrication is available on horizontal mounted units.
- **Sealing Options:** Cycloseal, Double mechanical seal, or packing is included in the list price. Run-dry option available.
- **Vertical Mounting:** Base elbows •  
**Horizontal Mounting:** Horizontal pump & motor bases are priced in solids handling accessories page.
- **Non-current Frame Models:** Available, consult factory for pricing.

30.00

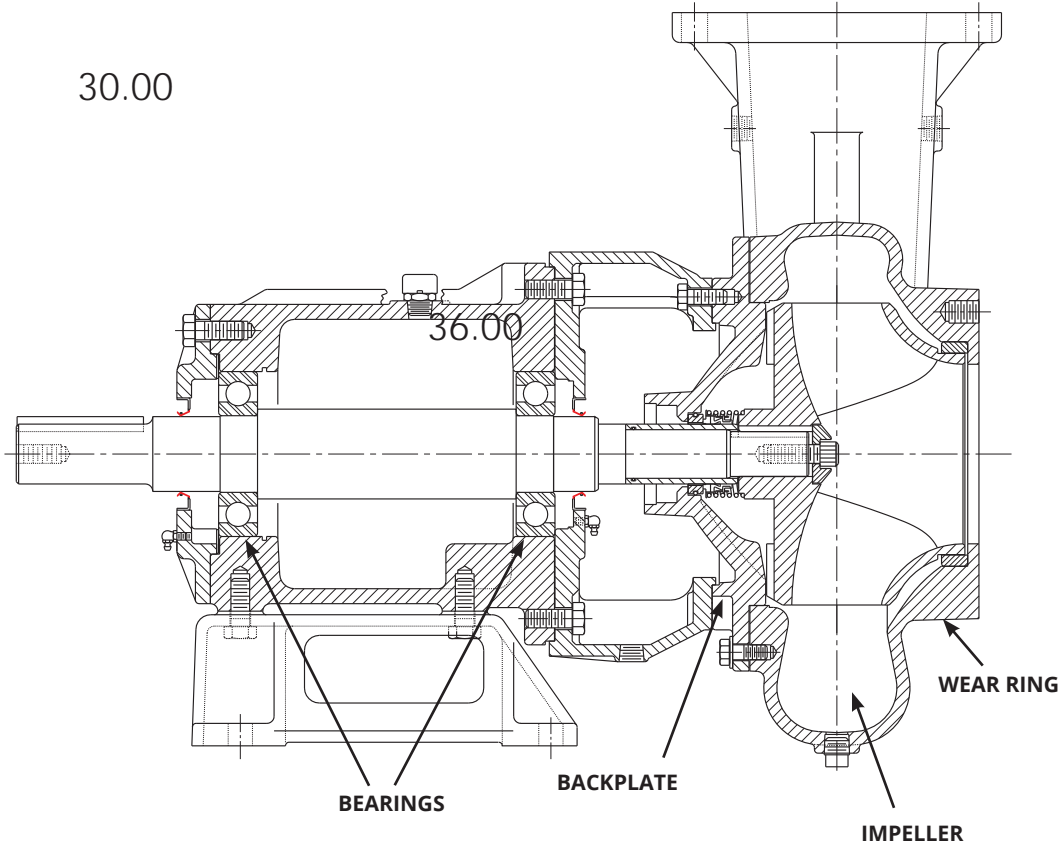

# 30NNT-F

## DATA SHEET

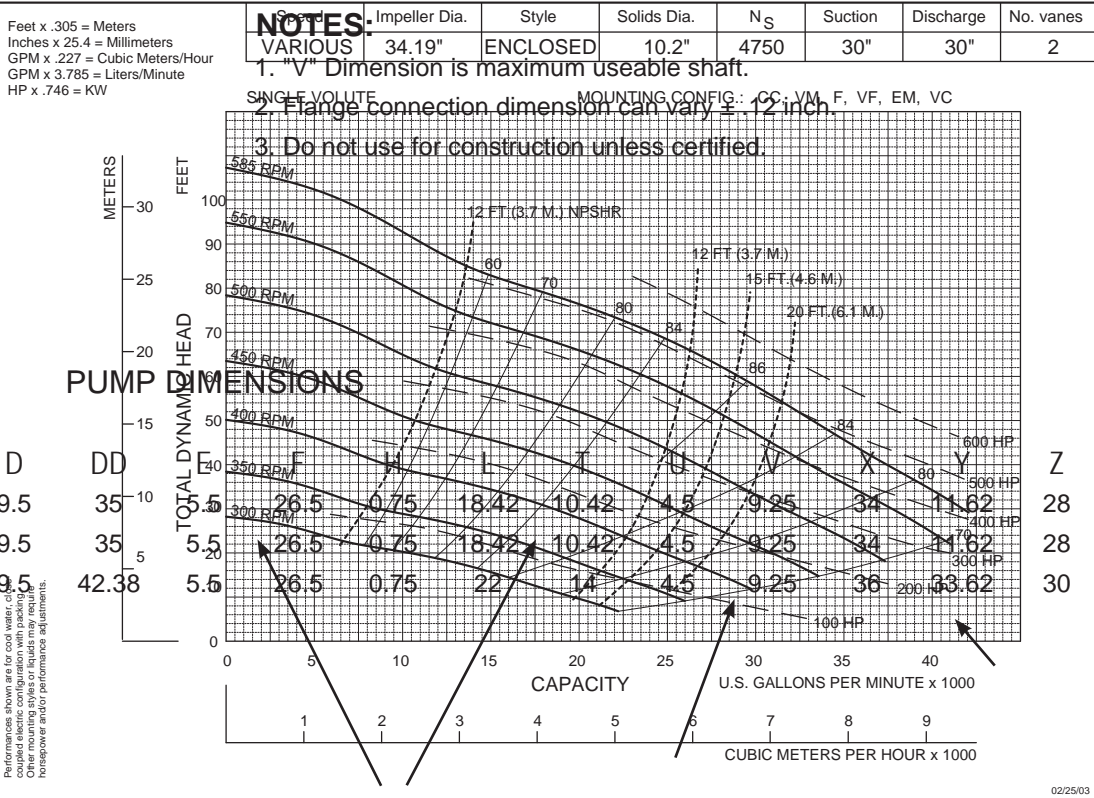
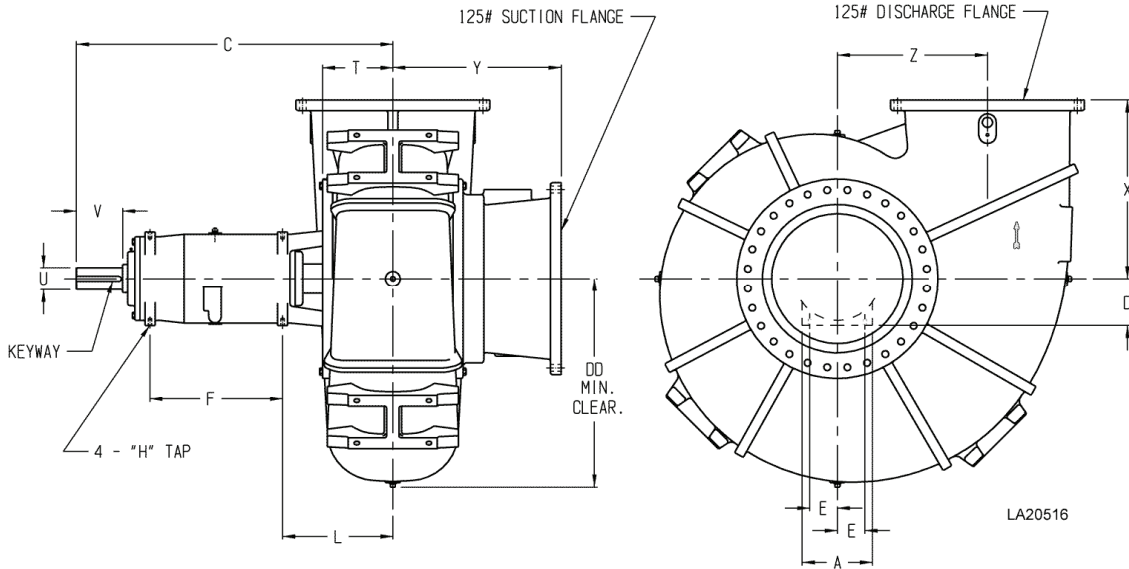

NEW PAGE

30NNTVA

Cornell Pump Company

Portland, Oregon

30NNT - VARIOUS RPM

10/10/08

SOLIDS HANDLING F30 HORIZONTAL FRAME MOUNTED PUMPS WITH CYCLOSEAL AND TANGENTIAL VOLUTE

DIM2037