

AVAILABLE MOUNTING CONFIGURATIONS

4HH-RP-F REDI-PRIME FRAME MOUNT
 4HH-F FRAME MOUNT
 4HH-RP-EM REDI-PRIME ENGINE MOUNT
 4HH-EM ENGINE MOUNT
 4HH-VF VERTICAL FRAME MOUNT
 4HH-VC VERTICAL COUPLED

OPERATING LEVELS

MIN FLOW	280 GPM	63.6 m ³ /h
MAX FLOW	1600 GPM	363.4 m ³ /h
DISCHARGE SIZE	4"	102 mm
SUCTION SIZE	6"	152 mm
SOLIDS HANDLING	.62"	1.6 cm
MAX SPEED	2300 RPM	2300 RPM
SHUT-OFF HEAD	422'	128.6 m
BEP HEAD	348'	106 m
BEP FLOW	1600 GPM	363.4 m ³ /h
BEP PERCENT	82%	82%



A typical picture of the pump is shown. Please contact Gemstone Pump Company for further details. All information is approximate and for general guidance only.

PARTS	CAST IRON BRONZE FITTED (STANDARD)	ALL IRON
IMPELLER	BRONZE SAE 40 OR SILICON BRONZE	CAST IRON ASTM A48 CL30
VOLUTE	CAST IRON ASTM A48 CL30	CAST IRON ASTM A48 CL30
SHAFT	SAE 1144 "STRESSPROOF"	SAE 1144 "STRESSPROOF"
SHAFT SLEEVE	BRONZE SAE 660	416 STAINLESS STEEL
BEARING HOUSING	CAST IRON ASTM A48 CL30	CAST IRON ASTM A48 CL30
WEAR RINGS	BRONZE SAE 660	CAST IRON ASTM A48 CL30
SUCTION SPOOL	CAST IRON ASTM A48 CL30	CAST IRON ASTM A48 CL30
BACKPLATE	CAST IRON ASTM A48 CL30	CAST IRON ASTM A48 CL30
MECHANICAL SEAL (OPTIONAL)	T-1, BUNA, CARBON/CERAMIC/STAINLESS	T-1, BUNA, CARBON/CERAMIC/STAINLESS
PACKING	GRAPHITED ACRYLIC	GRAPHITED ACRYLIC

The 4HH pump is designed with Gemstone's renowned quality and durability. It features a 4" discharge, 6" suction, enclosed impeller, and flanged tangential double volute. Available in all-iron or bronze-fitted materials. Graphited acrylic packing is standard, with Gemstone's patented Cycloseal® available (with type 1 single mechanical seal). Grease lubrication standard - oil lubrication optional.

- External hydraulic balance line
- Back pullout design
- Replaceable hub & suction wear rings
- Replaceable shaft sleeve
- High efficiency hydraulics
- Low operating costs
- SAE #1, 2, 3, 4 & 5 •
- Modular bearing frame •
- Oversized shaft and bearings
- Other mechanical seal (Cycloseal®) and material options available
- Two year warranty



AGRICULTURE



FOOD



INDUSTRIAL



MINING



MUNICIPAL



OIL & GAS



REFRIGERATION



RENTAL

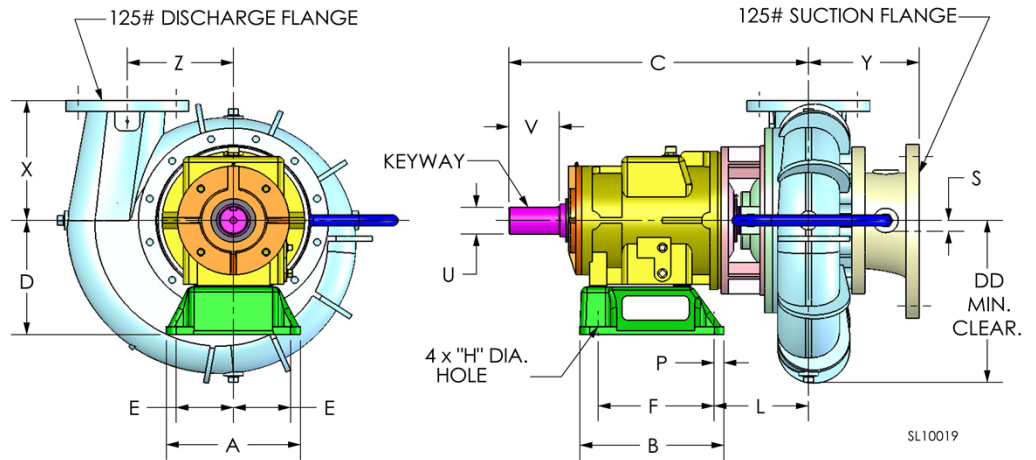

PUMP DIMENSIONS

MODEL	FRAME	CONNECTION		DISCH. INCR.	A	B	C	D	DD	E	F	H	L	P	S	U	V	X	Y	Z	KEYWAY
		DISCH.	SUCT.																		
3HA	F18	3	6	90°	12	12.88	29.11	10.5	11.12	5.12	10.38	0.81	10.74	0.88	0.44	2.5	4.5	10	8.53	8.5	.62X.31
3HC	F18	3	6	90°	12	12.88	25.88	10.5	11.12	5.12	10.38	0.81	7.5	0.88	0.44	2.5	4.5	10	8.53	8.5	.62X.31
4HC	F18	4	8	90°	12	12.88	26.97	10.5	12.62	5.12	10.38	0.81	8.6	0.88	0.88	2.5	4.5	11	10.88	9.75	.62X.31
4HH	F18	4	6	90°	12	12.88	29.14	10.5	15	5.12	10.38	0.81	10.77	0.88	0.44	2.5	4.5	9.5	8.97	11.25	.62X.31
5H	F18	5	8	90°	12	12.88	29.17	10.5	14.75	5.12	10.38	0.81	10.8	0.88	0.88	2.5	4.5	13	10.66	11.62	.62X.31
5HH	F18	5	8	90°	12	12.88	29.84	10.5	16.25	5.12	10.38	0.81	11.47	0.88	0.44	2.5	4.5	11	9.56	10.25	.62X.31
6H	F18	6	8	90°	12	12.88	29.14	10.5	14.75	5.12	10.38	0.81	10.77	0.88	0.44	2.5	4.5	14	10.18	11.62	.62X.31
6HH	F18	6	8	90°	12	12.88	30.13	10.5	17.12	5.12	10.38	0.81	11.91	0.88	0.44	2.5	4.5	12	10.43	12	.62X.31
8H	F18	8	10	90°	12	12.88	30.41	10.5	16.75	5.12	10.38	0.81	12.03	0.88	0.75	2.5	4.5	13	10.41	11.5	.62X.31

Feet x .305 = Meters
 Inches x 25.4 = Millimeters
 GPM x .227 = Cubic Meters/Hour
 GPM x 3.785 = Liters/Minute
 HP x .746 = KW

Speed	Impeller Dia.	Style	Solids Dia.	N _S	Suction	Discharge	No. vanes
VARIOUS	VARIOUS	ENCLOSED	.62"	1135	6"	4"	6

DOUBLE VOLUTE MOUNTING CONFIG.: CC, VM, F, VF, EM, VC

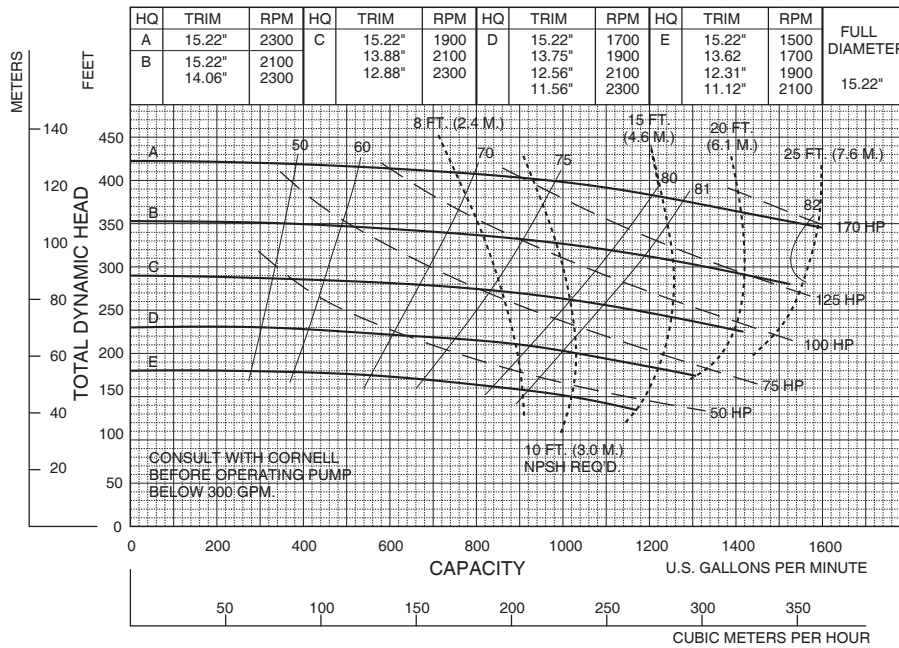

Performances shown are for cool water, close to ambient temperature.
 Other mounting styles or liquids may require horsepower and/or performance adjustments.

Gemstone Pump Company

4HH - VARIOUS RPM

9/6/00

NEW PAGE

4HHVA